

Simulation Based Decision Framework for Hybrid Layout Production Systems under Disruptions

V. Vijayan, R. Harikrishnakumar, and K. Krishnan

Department of Industrial, Systems, and Manufacturing Engineering
Wichita State University
Wichita, KS, USA

Corresponding author's Email: vishakhvijayan88@gmail.com

Author Note: A brief biographical sketch of the contributing authors goes here. It may include acknowledgment of funding sources, expressions of gratitude to research assistants, and contact information for the author who will handle requests.

Abstract: In a hybrid layout production system under uncertainties, making strategic decisions becomes crucial and demanding with increase in complexity of the system. Advent of Industry 4.0 lead to development of technologies such as smart factories, simulation, cloud, cyber physical systems which uses digital twins for making informed strategic decisions in a factory. This paper proposes a decision-making framework for a multi-product hybrid layout production system under stochastic disruptions using a simulation model. Simulation model will act as a digital twin of the physical system which helps to proactively visualize and analyze several key performance parameters of the system and make informed decisions. Objective of this paper is to identify the best sequence from pre-defined sequences for jobs which maximize profit, throughput, and minimize cost, and make-span. Several experimentation cases are developed to analyze performance of the system under different scenarios of disruptions and make strategic decisions such as investing in new machines, prioritizing products, and rescheduling of products.

Keywords: Industry 4.0, Decision-making, Simulation Model

1. Introduction

Advent of new age technologies Internet of Things (IoT), Cloud, Simulation, Autonomous Robots, System Integration, Cybersecurity, Additive Manufacturing, Data and Analytics, and Augmented Reality has led to formation of “smart factories”. The integration of above technologies is referred to as Industry 4.0 where humans, systems, and machines exchange information using network devices and sensors for coordinating and monitoring the processes in an industry. Industry 4.0 is the new phase of automation which integrates digital system with the physical counterpart using sensors and networking technologies. This concept is collectively referred to as Cyber-Physical Systems (CPS). In certain contexts, terms IoT and Industry 4.0 are used interchangeably. IoT is the most significant element of Industry 4.0. IoT comprises the connectivity element of the industry whether it is a production or service industry. The initial phase of both industries involves exchange of information between several entities of an industry. In the case of manufacturing of products, initially an idea is converted into a design drawing using CAD software from physical objects either by scanning or creating data. They are analyzed and finalized using digital technologies and finally manufactured as a physical entity. Even after beginning of the production process, information is shared frequently between systems, machines, and humans for analysis and improvement on a real time basis depending on parameters that govern the entire process. Industry 4.0 improves the ability to design, analyze, modify, create, and customize faster by lowering factors such as cost, lead time, and adapting to changes in demand, preferences, and technology.

Industry 4.0 is made possible by the connectivity of all the entities which are directly or indirectly part of the network through a cloud network using connectivity devices to send and receive data and to manage the system remotely. This concept is termed as Internet of Things or IoT and gave rise smart factories and decentralized management of systems. IoT uses real-time data from automated machines linked together through internet connectivity and analyze them to make real-time decisions. Digital twin concept emerged with simulation and IoT where a digital model accurately represents a physical system of a production process or a service industry. Using design, analysis, simulation, and manufacturing, users can recreate and verify original physical model of production system. It connects real world data with the systems model and let the user interpret, analyze and make decisions based on the data received on real time. It has several advantages the most important of which is the ability to improve performance of the process irrespective of whether it is manufacturing or service. It helps the users to make critical decisions under uncertain conditions of disruptions, demand variation, service requests, market fluctuations, and

technology changes etc. so that the real system performance is not affected by these uncertainties. Manufacturing facilities running by integration of all these technologies are currently referred to as Smart factories. Smart factories which uses digital twins collects real time data from factory using sensors, motors, and robotics and upload it to the cloud. This information is accessible to users at different levels in the factory such as floor managers, plant managers or regional managers etc. Digital twin helps to visualize the real time changes of the system on monitoring and control devices such as PCs, tablets, or phones. Combined with other techniques such as simulation, optimization, and machine learning techniques managers can analyze and make real time strategic decisions to improve the performance of the physical system. Techniques chosen for analyzing the digital twin, to make managerial decisions, depends on several factors such as investment cost, time for obtaining the solutions, expected performance improvement and cost-profit trade-off, size and complexity of the system etc. Machine learning algorithms, optimization techniques such as mathematical models, heuristics and meta-heuristics, simulation and statistical analysis are commonly used techniques for analysis. Simulation is a low-cost technique for analyzing digital twins which helps to visualize the physical system and enables to run different scenarios to make statistical and prescriptive analysis. Simulation results can be used as a baseline for managerial decisions and determine the key aspects of the system to understand its operations. Analysis of these different scenarios provide insights on existing systems and for designing future systems. Simulation also provides important insights about the physical model when working under stochastic conditions and helps the user for making decisions to tackle the obstacles without affecting the performance of the physical system. Simulation has been widely used in manufacturing industries and it helps in making critical decisions on job scheduling, investment on machines, operators, purchasing etc. Job scheduling problems are NP-hard problems requiring complex computations for determining the strategic decisions and optimize performance of the system. Factors such as stochastic disruptions, layout of the facility, demand, service level required, arrival rate of materials, processing cost etc. influence performance of the system significantly. The primary objective of this paper is to investigate effect of disruption on the performance of a hybrid layout production system. A decision-making framework using simulation with random disruptions is created to make informed strategic managerial decisions. Simulation combined with statistical analysis and prescriptive analysis is used to investigate the system under different settings of machine disruptions, product type, buffer limits and frequency levels of disruption to quantify the impact of disruption in terms of cost, profit, revenue, makespan and machine utilization. As secondary objectives, prioritizing of products based on per unit profit and decisions on investing in new machines is also studied. The simulation model will perform as a decision-making tool for analyzing different possible scenarios to develop strategies and policies for managers to improve performance parameters.

2. Literature Review

Job scheduling problems are those problems for determining a sequence or order of assigning machines for doing certain job in a production system such that the performance of the system is optimum or near optimum. They are considered as Non-deterministic Polynomial-time hardness problem or NP Hard problem due to the high computational time required for solving such problems. Zhang and Ding et al. (2017) peer reviewed job scheduling problems and its perspectives under Industry 4.0. First mathematical model for scheduling was done by Johnson (1954) for scheduling of two machines. Different approaches have been used for solving such scheduling problems. They are broadly classified into Analytical approach and graphical approach by Yoo (1977). Analytical approaches include mathematical models, heuristics and meta-heuristics for objective parameters such as minimizing makespan, cost, Work-in-Progress (WIP) etc. The graphical approach uses Gantt charts, simulation etc.

A two-stage hybrid flowshop problem is empirically evaluated to minimize makespan using a heuristic algorithm by Jatinder (1988). The paper assumes replicates of machines at each stage and found that makespan increase with increase in job arrivals. They used FORTRAN to solve the problem using the proposed algorithm. Gupta et al. (1997) considered a problem of two-stage flowshop with identical machines in the first stage and single machine in the second stage with the objective of minimizing makespan. They used branch and bound, and heuristics to construct an algorithm producing optimal and near optimal solutions. The paper proposes a larger and complex problem scenario for future work. Inclusion of other performance parameters such as maximum tardiness, cost etc. are also topics for further research. Simulation modeling was used by Eric and Wade (1998) in their paper for dynamic job shop rescheduling with machine availability constraints due to breakdown or maintenance. Sensitivity of rules were analyzed towards changes in breakdown rates, processing time distributions and AGV priority schemes in the paper by Sabuncuoglu (1998) for Flexible Manufacturing Systems (FMS). Mean flow time was considered as the objective function against the scheduling rules of machines and AGVs. A preventive maintenance breakdown (PMBD) heuristic was developed using AWESIM modeling tool and a visually interactive simulation model is created. Heng et al. (2000), developed an expert simulation system incorporating simulation technique, artificial neural network, dispatching and expert knowledge rules for job shop rescheduling subjected to incorrect work, machine breakdowns, rework and rush orders. They used Foxpro 5.0 and Matlab 4.0 to create the simulation model and fuzzy network. Girish and Nallan (2000)

compared hybrid cellular manufacturing (CM) system with functional layout under different operating conditions to investigate performance measures - flow time, work-in-process inventory, flow ratio and machine utilization. Factors studied comprise system, setup factor, degree of part family similarities, lot size and scheduling rule. Scheduling rules which are part family-oriented outperforms job shop rules. Future work incorporating labor aspects along with machine-related constraints will provide more insights into the performance of CM systems.

Lixin et al. (2005) proposed a neural network model and algorithm for hybrid flow shop scheduling in a dynamic scenario. They used simulation with neural network to investigate performance of dispatching rules. Training method of the neural network is optimized using delta-bar-delta (DBD) method for faster training convergence. Simulation showed neural network approach to be more effective than traditional dispatching rules. Other than dynamic job arrivals, including machine breakdown, order cancellation, and rush orders have scope for future work. Expected makespan and expected mean tardiness are minimized by integrating simulation into genetic algorithm by Gholami and Zandieh (2009). They included stochastic unavailability due to breakdowns or due to scheduled preventive maintenance. They used right-shift heuristic approach and event driven policy in the algorithm to evaluate expected makespan and expected mean tardiness values. Using random arrival times, other distributions for time active and time to repair for machines have scope for future research.

Simulation is used to analyze performance of different layouts under stochastic conditions by Krishna et al. (2009). Performance of Distributed layout with minimum-part-order splitting (DL-MOS) is compared with process layouts with objective functions work-in-process, material handling cost and cycle time. DL-MOS outperformed process layout in material handling cost, makespan and WIP. Manufacturing systems subjected to perturbations such as machine failures, queuing techniques and dynamic product route change based on availability may show variations in performance due to uncertainties and hence a detailed study is suggested as future research. Mirabi et al. (2013) proposed a heuristic algorithm for minimizing makespan of a two-stage hybrid flow shop with optimal job combinations and job schedule under breakdown conditions. Paper suggests increasing complexity of the problem for future research and increasing number of machines in the first stage.

Zhe and Xingsheng (2014) uses artificial bee colony (IDABC) algorithm for minimizing makespan for HFS problem using vector representation. It integrates differential evolution and variable neighborhood search for generating new solutions. Studying interaction between parameters with stochasticity and multi-objective scheduling cases are suggested for future work. Siyavash and Hadi (2014) used simulation for comparing job shop and group technology. Productivity and queue factors of the two production systems are compared. Prioritizing products, adding stochasticity, increasing the scale of the problem etc. are areas for future work. FJS problem with parallel batching machines was analyzed for minimizing number of tardy jobs and makespan in the paper by Andrea et al. (2014). Two new heuristics were proposed using critical ratio of allowance of set-up and time to process in scheduling horizon. A simulation optimization approach is used by James and Chien-Ming (2015) for HFSSP for minimizing flow time. Genetic algorithm is used for optimizing the strategy adopted for scheduling at different demand, product mix, and lot sizing levels. Offline and online scheduling problems in JSS are investigated by Chen and Theodore (2015). They used simulation modeling tool with JSS under dynamic and static problem settings. Mohammed and Thomas (2017) developed Iterative Optimization based Simulation (IOS) model for evaluating performance of optimizers. They proposed a CallMATLAB step instance for integrating computational resource to the simulation package SIMIO to embed optimization techniques in simulation. A mixed integer programming (MIP) model is proposed for two-stage HFS scheduling problem with dedicated machines, sequence-dependent family setup times, and time lags to minimize makespan by Harbaoui et al. (2016). Genetic algorithm is combined with the MIP for solving the problem and tested it on multiple parallel identical machines in the second stage. In the reviewed papers, the objective functions considered are mainly makespan, tardiness, WIP, single objective in most cases, whereas detailed investigations on other parameters of interests such as cost, profit, throughput and material handling are limited. Most papers show that rescheduling of jobs under stochastic conditions affect the performance of a system under normal conditions. A general framework for rescheduling of jobs under stochasticity is not present and it is important to do a detailed study from managerial perspective considering these aspects.

3. Methodology

In this chapter, detailed description of problem is given along with the assumptions and methodology adopted for creating the simulation model for experimental analysis. Production systems are subjected to several uncertainties due to factors such as variation in demand, arrival rate, processing times, disruptions etc. Inclusion of these uncertainties in a digital twin is important to make the production system model realistic. In this paper, a multi-product hybrid layout production system subjected to machine disruption is investigated using simulation model. Production systems performance are affected by perturbations and output parameters may vary based on the severity and frequency of disruptions. Crucial informed proactive decisions need to be made based on available information and analysis to reduce the impact of disruption on the normal performance of the system. A simulation modeling approach is used to create a decision-making framework to visualize the real system and gather insights on the performance of the system under various conditions which aid to make managerial

decisions such as rescheduling based on cost and makespan, prioritizing of products based on profit, and investing in new machines. Simulation model will serve as a digital twin which gives real time visual feedback of the production floor and let the users analyze, interpret, plan, or make real time decisions based on the variations in different factors that affect the performance of the process. Jose et al. (2019) determined that event-based scheduling gives better results than continuous rescheduling. This paper aims to identify the best sequence for randomly arriving jobs from a set of predefined sequences for each job type under disruption scenarios with objectives of minimizing cost, makespan, and maximizing profit and throughput. Determining balking condition in the input buffer at each machine and decision on investment on new machines are the secondary objectives in this paper. Machine utilization is considered when analyzing the performance of the process to make decisions on addition of new machines or removing under-utilized machines.

3.1 Simulation Model

First part of this research involved creation of a hybrid layout production system model using SIMIO with multiple products which are assigned predefined primary sequences and alternate sequences.

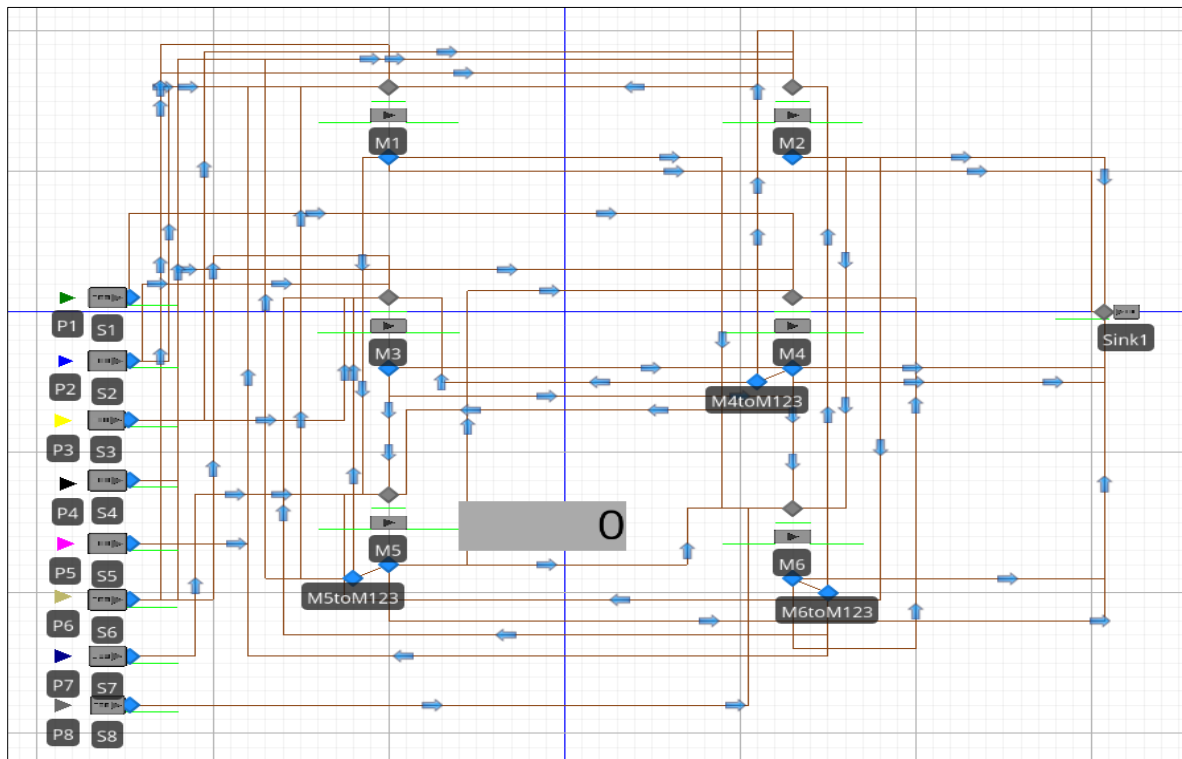

Figure 1. Simulation model in SIMIO

A model framework of a production system with six machines is considered as the initial model. Machines are considered as servers in Simio and six servers are created with paths interconnecting all the servers, source, and sink. Source, and sink respectively acts as starting and end points for the parts arriving in the system. The layout of the system is adopted from the paper by Krishnan et al. (1990). Parts or products are created using entities and for this model, eight products are considered, and eight entities are created with different colors to distinguish each part type. Using the user defined processes in SIMIO, custom logic such as rescheduling an entity when a machine undergoes disruption are created and behavior of entities during disruptions are also defined. For making the model realistic, stochasticity is applied for part arrival, processing times, disruption frequency, and repair time. Processing times follow random triangular distribution and they are sequence and part type dependent. Part arrivals are based on random Poisson distributions of inter-arrival time and each part type are assigned a fixed selling price. A hybrid layout with six machines are selected with three machines capable to carry out same process with different processing time and cost. For the three machines M_1 , M_2 , M_3 , cost of machining is assumed to be different such that

they are prioritized based on cost. Multiple part types are assumed for this research, each part type with three alternate sequences with least cost sequence as the primary sequence. When a machine undergoes disruption, the parts arriving is assigned to the next best sequence from the predetermined sequences. The second phase of this research involves extensive experimental analysis by developing different cases of simulation under different levels of input parameters such as number of machines under disruption, disruption frequencies, number of alternate sequences, number of products, for making informed managerial decisions for minimizing cost, makespan or maximizing profit and throughput.

Assumptions:

1. Parts arrive in single units for a part type
2. Unit parts arrive following a random Poisson distribution
3. Disruption occur at intervals of random exponential distribution of processing time
4. Infinite buffer capacity at each machine
5. FIFO queueing policy
6. Processing time is sum of set-up, processing, and tear-down time

3.2 Formulation

P_i – Part types

M_j – Machine number

$T_{i,j}$ – Processing time of P_i in M_j

C_j – Cost of processing per minute in M_j

S_i – Selling price of P_i

Processing Cost for part $P_i = \sum (C_j \times T_{i,j})$

Makespan of part $P_i = \sum T_{i,j}$

Profit per part $P_i = S_i - \sum (C_j \times T_{i,j})$

Percentage utilization of machine $M_i = \frac{\text{Total Time Processing}}{\text{Total time available for machining}}$

Total machining cost of $M_i = \text{Total Time Processing} \times C_j$

Initial model consists of eight distinct part types with different arrival rates. An arrival table with arrival rates following random Poisson distribution is created for each part type to integrate stochasticity in the model. Processing times also following random triangular distributions are assigned for each alternate sequence for all job types. Table 1 shows the predefined processing sequences for each part type with details of machine number, processing times and processing costs. Parts are assumed to have selling-price as shown in Table 2 and profit of parts are calculated as difference between selling price and processing cost.

Table 1. Part sequences with mean processing times and machining costs at each machine

	P_i	M_j	C_j	$T_{i,j}$	Machining Cost	M_j	C_j	$T_{i,j}$	Machining Cost	M_j	C_j	$T_{i,j}$	Machining Cost	Total $T_{i,j}$	Cost per P_i
Seq	P1	M4	0.3	15	4.5	M1	0.3	25	7.5	M6	0.5	21	10.5	61	22.5
	P1	M4	0.3	15	4.5	M2	0.6	15	9	M6	0.5	21	10.5	51	24
	P1	M4	0.3	15	4.5	M3	0.4	28	11.2	M6	0.5	21	10.5	64	26.2
	P2	M2	0.6	19	11.4	M6	0.5	17	8.5				0	36	19.9
	P2	M3	0.4	31	12.4	M6	0.5	17	8.5				0	48	20.9
	P2	M1	0.3	42	12.6	M6	0.5	17	8.5				0	59	21.1
	P3	M3	0.4	21	8.4				0				0	21	8.4
	P3	M2	0.6	12	7.2	M1	0.3	19	5.7				0	31	12.9
	P3	M2	0.6	22	13.2				0				0	22	13.2
	P4	M1	0.3	40	12				0				0	40	12
	P4	M3	0.4	35	14				0				0	35	14
	P4	M2	0.6	27	16.2				0				0	27	16.2

P5	M5	0.4	15	6	M2	0.6	29	17.4				0	44	23.4
P5	M5	0.4	15	6	M1	0.3	30	9	M ₃	0.4	25	10	70	25
P5	M5	0.4	15	6	M3	0.4	53	21.2				0	68	27.2
P6	M1	0.3	20	6				0				0	20	6
P6	M3	0.4	18	7.2				0				0	18	7.2
P6	M2	0.6	14	8.4				0				0	14	8.4
P7	M5	0.4	25	10	M4	0.3	20	6				0	45	16
P7	M5	0.4	25	10	M4	0.3	20	6				0	45	16
P7	M5	0.4	25	10	M4	0.3	20	6				0	45	16
P8	M6	0.5	32	16				0				0	32	16
P8	M6	0.5	32	16				0				0	32	16
P8	M6	0.5	32	16				0				0	32	16

Table 2. Selling price of each part type

Part Type	Selling Price
P1	30
P2	26
P3	15
P4	18
P5	31
P6	12
P7	20
P8	22

4. Implementation

The simulation model created acts as a digital twin for the production system with hybrid layout and processing multiple products. This chapter describes cases developed for experimental analysis for determining the performance of the model under different working conditions at different levels of the parameters - disruption frequency, product variety, buffer limit condition for balking.

4.1 Case Definition

For verifying the performance of the model as a decision-making framework for informed managerial decisions such as capital investment on new machines, assigning alternate sequences for jobs, determining product priority to increase profit etc., different cases are developed for analyzing and comparing the results to make significant insights. Table 3 shows the different cases developed for experimental analysis.

Table 3. Cases

Case Number	Machines undergoing disruption
Case 1	No Disruption
Case 2	M_1
Case 3	M_1, M_3
Case 4	M_1, M_2, M_3

4.1.1 Case – 1

Case – 1 is the initial model created with all the machines assumed to be available for processing throughout the simulation span. The simulation is run for a span of fourteen days with eight product types having arrival rates as mentioned in the previous chapter. All part types follow their primary part sequence with minimum cost. Assuming event-based rescheduling, there is no rescheduling of products in this case as there are no disruptions of machines and thereby no unavailability of machines. The results are expected to give maximum throughput and profit at minimum cost compared to cases with disruptions. The buffer quantity at individual machines are expected to be minimum and machine utilization is such that all machines are utilized with capacity to incorporate additional load. The result from this ideal case will be used as a benchmark for comparing the results obtained from cases with disruption.

4.1.2 Case – 2

This case assumes the system is subjected to minor disruption. For that M_1 , assumed to be least expensive machine, undergoes breakdown. Disruption frequency depends on the processing time between failures. Disruption frequency follows a random exponential distribution as it gives distribution closer to realistic values for frequency of disruptions. The cases are then run in two scenarios – first scenario, 2(a), assumes only one sequence for products, and they are not rescheduled in case of disruption, second scenario, 2(b) uses alternate sequence when M_1 is disrupted. When disruption occurs in second scenario, products already waiting in buffer and machine wait until the machine becomes active. Products waiting to be routed to M_1 are rescheduled to their secondary sequence which will have higher processing cost. Utilization of M_1 is expected to decrease as time available for processing during simulation run decreases due to disruption and products are rescheduled to the next available machine. Utilization of M_2 and M_3 are expected to increase as the parts are rescheduled. Cost of machining and makespan are also expected to increase for rescheduled parts.

5. Results & discussion

Simulation identifies the best sequence from the available alternate sequences. Figure 4 shows Gantt chart with sample sequence of products in a certain period in the simulation. Following sections describe results obtained after running the simulation in different cases.

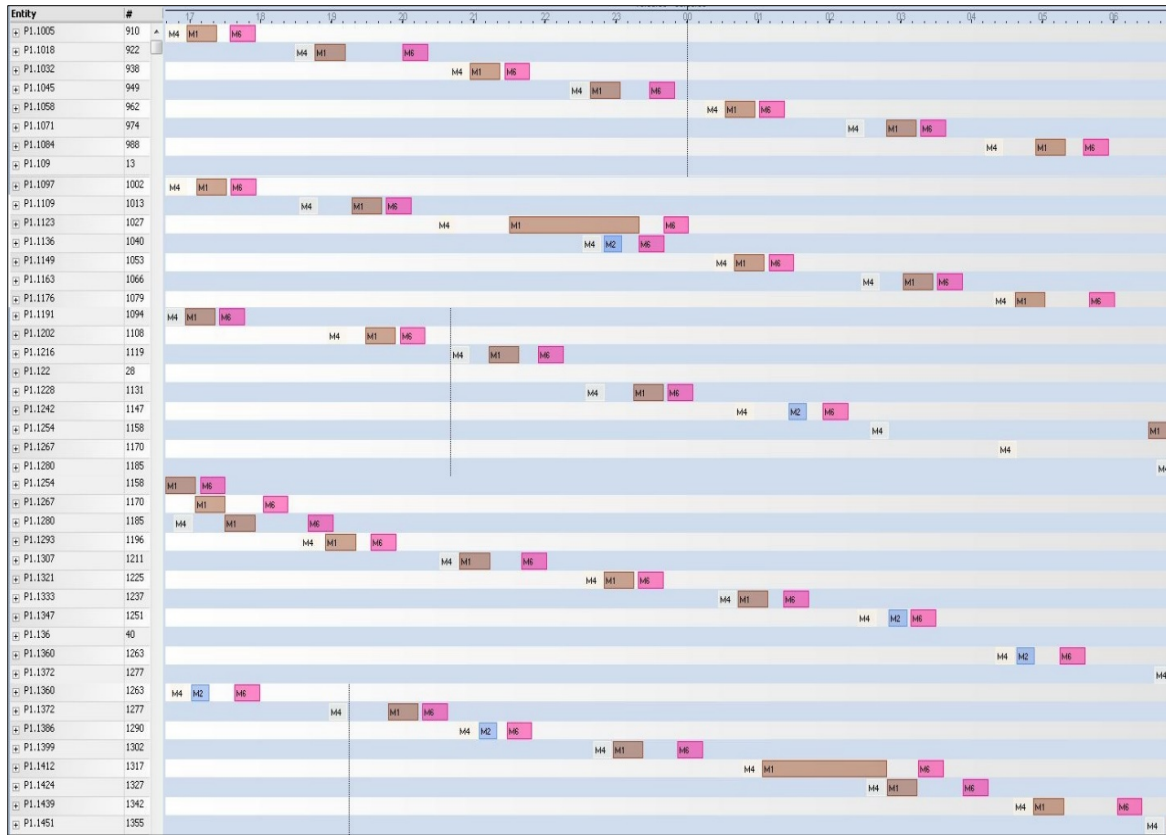

Figure 2. Sample result showing individual part sequences in a sample time interval

5.1.1 Case 1

For comparing performance of various scenarios of disruption such as number of machines undergoing disruption, machine disruption frequency levels, an ideal scenario is required in which machines are assumed to be available throughout the simulation run time. Case-1 assumes machines does not undergo disruptions and system will be working at minimum cost sequences and maximum throughput. The tables 4 & 5 show different performance parameters of the system such as machine utilization percentage, cost of machining, throughput and revenue. Total revenue, cost, and throughput are shown, and remaining cases aims to minimize the effect of disruptions on these parameters.

Table 4. Case 1- Machine Utilization and Cost of Machining

Machines	Machine Utilization (%)	Cost of Machining (\$)
M1	99.56	6021.63
M2	75.27	9104.46
M3	73.65	5938.80
M4	75.96	4594.28
M5	93.25	7520.04
M6	99.52	10031.30
Total		43210.51

Table 5. Case 1 - Cost per unit, makespan, revenue and throughput

Parts	Cost per Unit (\$)	Makespan (min)	Revenue (\$)	Throughput (units)
P1	22.50	8.09	6450.00	215.00
P2	19.90	3.53	10400.00	400.00
P3	8.40	0.38	10605.00	707.00
P4	12.00	4.76	3870.00	215.00
P5	23.40	1.08	7936.00	256.00
P6	6.00	4.55	3600.00	300.00
P7	16.00	0.95	11940.00	597.00
P8	16.00	3.21	6006.00	273.00
Total			60807.00	2963.00

5.1.2 Case 2

In this case, system is assumed to undergo disruption with respect to exponential distribution of processing time of a machine between failures. The disruption is restricted to only M_1 in this case. The simulation is run in two different scenarios of using only one sequence and two sequences when disruption occurs. As the rescheduling of jobs is event based, rescheduling only occurs when disruption occurs. Hence when M_1 undergoes disruption, case - 2(a) assumes only one sequence and as a result the makespan of the products are expected to increase with increase in number of jobs in the input buffer of disrupted machine. In case – 2(b), two sequences are used, and products uses second sequence when M_1 is disrupted. The cost of machining increases and makespan decreases compared to using only one sequence. As a result, throughput and revenue increases when using an alternate sequence. The values show that cost and throughput are closer to the ideal case when using two sequences when M_1 is under disruption. The utilization of machines M_2 and M_3 increases as more products are scheduled to these machines under disruption. M_1 utilization reduces to 88.58% and 88.51% in 2(a) and 2(b) respectively from 99.56% in ideal case as the machine is subjected to disruption and is not available during this span of simulation. Other machine utilizations remain nearly same as in the ideal case as there is no change in number of jobs assigned for machining.

Table 6. Case 2 - Machine utilization and cost of machining

Machines	Machine Utilization (%)			Cost of Machining (\$)		
	Case 1	Case 2		Case 1	Case 2	
		2(a)	2(b)		2(a)	2(b)
M1	99.56	88.58	88.51	6021.63	5357.62	5352.85
M2	75.27	75.27	77.10	9104.46	9104.46	9325.42
M3	73.65	73.65	80.59	5938.80	5938.80	6498.84
M4	75.96	75.96	75.96	4594.28	4594.28	4594.28
M5	93.25	93.25	93.25	7520.04	7520.04	7520.04
M6	99.52	98.33	99.52	10031.30	9911.75	10031.30
Total				43210.51	42426.95	43322.73

Table 7. Case 2 - Cost per unit, makespan, revenue and throughput

Parts	Cost per Unit (\$)		Makespan (min)		Revenue (\$)		Throughput (units)	
	2(a)	2(b)	2(a)	2(b)	2(a)	2(b)	2(a)	2(b)
P1	22.50	22.67	24.46	8.03	5790.00	6450.00	193.00	215.00
P2	19.90	19.90	1.47	3.54	10556.00	10400.00	406.00	400.00
P3	8.40	8.40	0.38	0.51	10605.00	10575.00	707.00	705.00
P4	12.00	12.22	23.10	4.72	3438.00	3870.00	191.00	215.00
P5	23.40	23.40	1.08	1.09	7936.00	7936.00	256.00	256.00
P6	6.00	6.13	22.78	4.55	3204.00	3588.00	267.00	299.00
P7	16.00	16.00	0.95	0.95	11940.00	11940.00	597.00	597.00
P8	16.00	16.00	1.15	3.21	6094.00	6006.00	277.00	273.00
Total					59563.00	60765.00	2894.00	2960.00

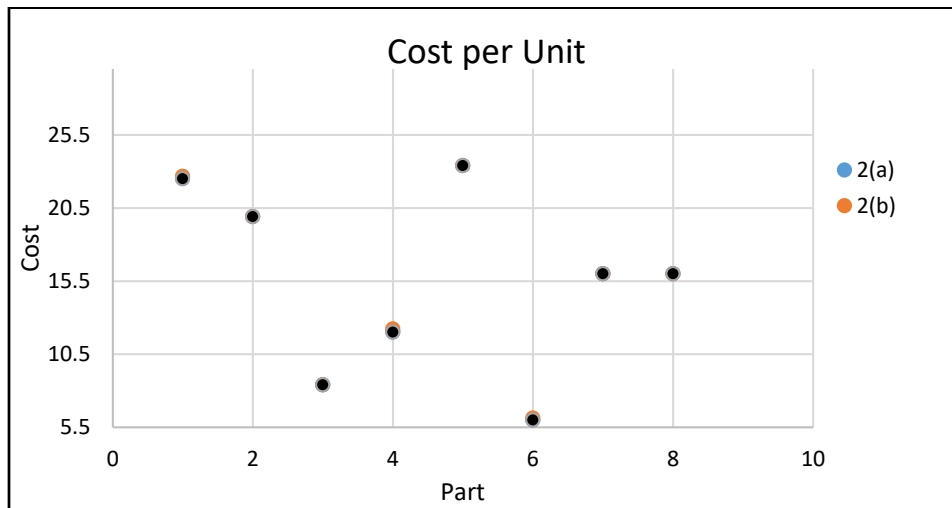

Figure 3. Case 2, Cost per unit vs part type

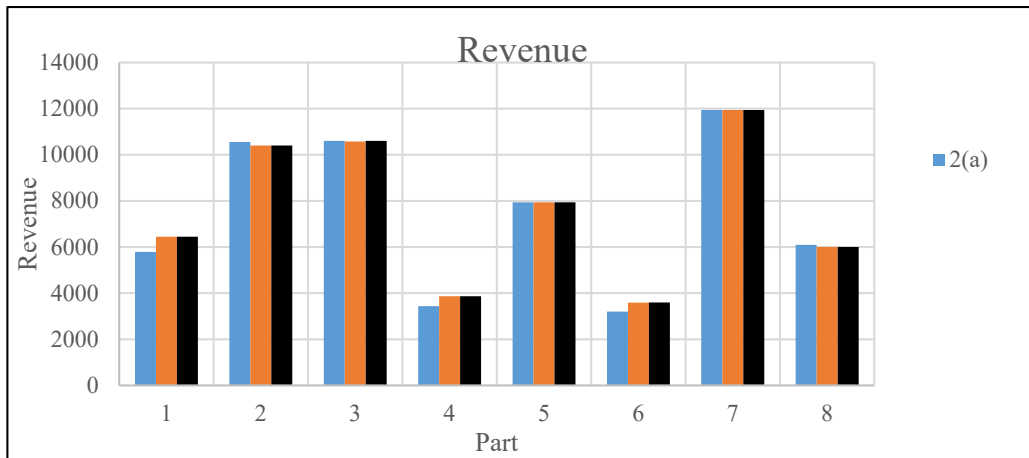

Figure 4. Case 2, Revenue vs part type

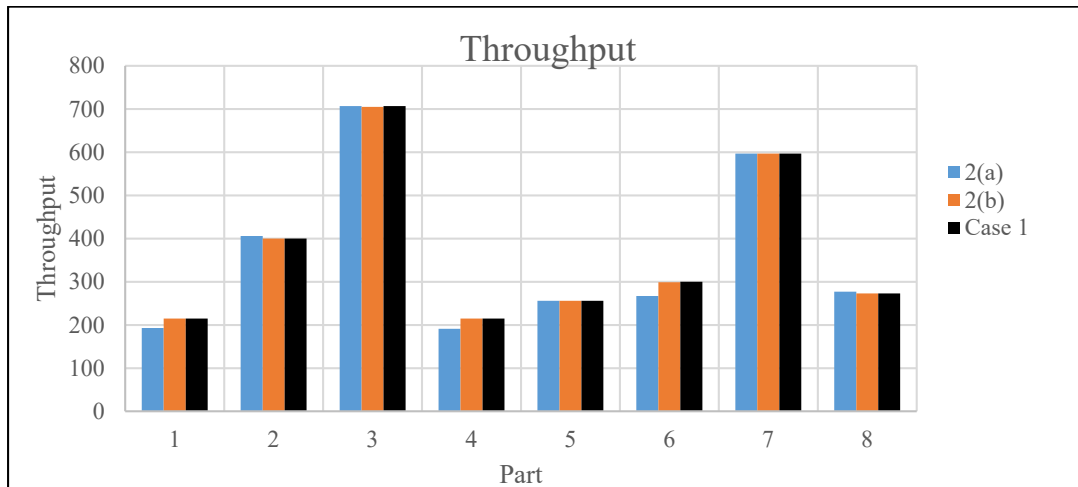

Figure 5. Case 2, Throughput vs part type

Table 8. Case 2 – Total cost, total throughput, and total profit with number of sequences

Case No:	Revenue (\$)	Throughput (units)	Profit (\$)
Case 1	60807	2963	17596
2(a)	59563	2894	17136
2(b)	60765	2960	17442

Table 8 shows that under disruption, two sequences increases the throughput and profit with compromise in cost as the total cost is found to increase. Single sequence will build up buffer at disrupted machine with reduced throughput and profit. Two sequence performance is much closer to ideal case of no disruption. Figures 8, 9, & 10 shows the graphical representation of revenue, throughput and profit. Utilization of M_1 , and M_3 from the results shows that alternate sequence can be used, and system can incorporate perturbations.

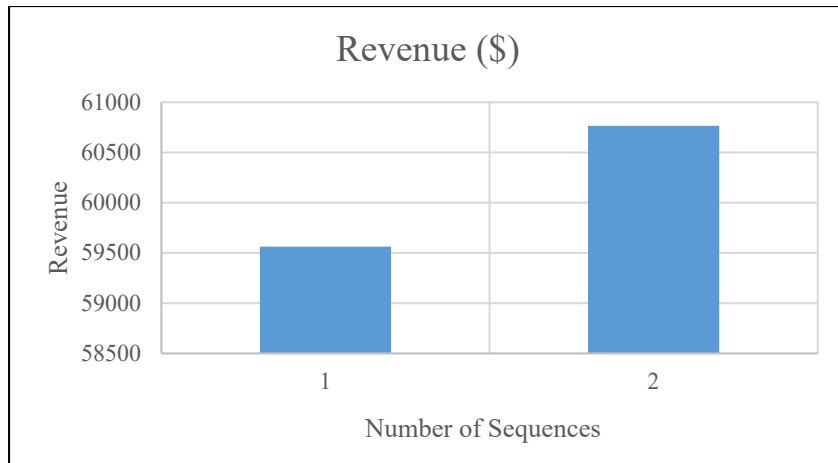

Figure 6. Case 2, Revenue vs Number of Sequences

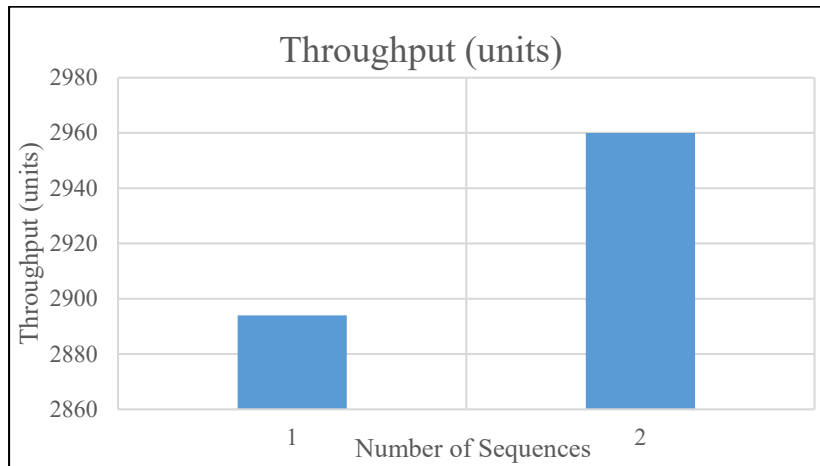

Figure 7. Case 2, Throughput vs Number of Sequences



Figure 8. Case 2, Profit vs Number of Sequences

6. Conclusion and Future Work

A decision framework for a multi-product hybrid layout production system under real-time random disruptions using simulation models is created. Simulation model generates schedules for parts arriving randomly from predetermined schedules. Various cases are developed with different disruption conditions to verify the robustness of model and for making informed managerial decisions in product prioritization, product routing, scheduled utilization of machines, capital investment in machines etc. Initial case studies show that the model selects product routes from predetermined schedule according to objective parameter processing cost considering profit, makespan, and throughput. Disruption reduces throughput, and profit whereas cost, and makespan increases. Using alternate schedule reduces the effect of disruption on objective parameters. As expected, the system performance varies when using different number of alternate sequences. Initial experimentation results show that increasing number of alternate sequences doesn't always improve the performance of the system.

Initial phase of the thesis uses eight products, fixed frequency level of disruption, and infinite buffer capacity. Further insights can be determined on the performance of the system by increasing number of products. Increasing frequency level of disruption also lets the users to make decisions of whether to invest in new machines or prioritizing products based on profit under perturbations. Performance parameters are analyzed under event-based rescheduling in the initial phase. Rescheduling based on input buffer quantity at each machine will also give more insights on system performance under disruption. Integration of real-time optimization with simulation under perturbations with same or higher complex system has scope for future work.

7. References

- Amiri, F., Shirazi, B., & Tajdin, A. (2019). Multi-objective simulation optimization for uncertain resource assignment and job sequence in automated flexible job shop. *Applied Soft Computing*, 75, 190–202. doi: 10.1016/j.asoc.2018.11.015
- Cui, Z., & Gu, X. (2015). An improved discrete artificial bee colony algorithm to minimize the makespan on hybrid flow shop problems. *Neurocomputing*, 148, 248–259. doi: 10.1016/j.neucom.2013.07.056
- Dehghanimohammadabadi, M., & Keyser, T. K. (2017). Intelligent simulation: Integration of SIMIO and MATLAB to deploy decision support systems to simulation environment. *Simulation Modelling Practice and Theory*, 71, 45–60. doi: 10.1016/j.simpat.2016.08.007
- Dong, Y.-H., & Jang, J. (2012). Production rescheduling for machine breakdown at a job shop. *International Journal of Production Research*, 50(10), 2681–2691. doi: 10.1080/00207543.2011.579637
- Gholami, M., & Zandieh, M. (2008). Integrating simulation and genetic algorithm to schedule a dynamic flexible job shop. *Journal of Intelligent Manufacturing*, 20(4), 481–498. doi: 10.1007/s10845-008-0150-0
- Gupta, J. N. (1988). Two-Stage, Hybrid Flowshop Scheduling Problem. *Journal of the Operational Research Society*, 39(4), 359–364. doi: 10.1057/palgrave.jors.0390404
- Harbaoui, H., Morineau, O. B.-, & Khalfallah, S. (2016). Scheduling a two-stage hybrid flow shop with dedicated machines, time lags and sequence-dependent family setup times. *2016 IEEE International Conference on Systems, Man, and Cybernetics (SMC)*. doi: 10.1109/smc.2016.7844695
- He, W., & Sun, D.-H. (2012). Scheduling flexible job shop problem subject to machine breakdown with route changing and right-shift strategies. *The International Journal of Advanced Manufacturing Technology*, 66(1-4), 501–514. doi: 10.1007/s00170-012-4344-4
- Li, H., Li, Z., Li, L. X., & Hu, B. (2000). A production rescheduling expert simulation system. *European Journal of Operational Research*, 124(2), 283–293. doi: 10.1016/s0377-2217(99)00381-1
- Li, Y.-C. E., & Shaw, W. H. (1998). Simulation modeling of a dynamic job shop rescheduling with machine availability constraints. *Computers & Industrial Engineering*, 35(1-2), 117–120. doi: 10.1016/s0360-8352(98)00034-5
- Mirabi, M., Ghomi, S. M. T. F., & Jolai, F. (2011). A two-stage hybrid flowshop scheduling problem in machine breakdown condition. *Journal of Intelligent Manufacturing*, 24(1), 193–199. doi: 10.1007/s10845-011-0553-1
- Rooeinfar, R., Raissi, S., & Ghezavati, V. (2018). Stochastic flexible flow shop scheduling problem with limited buffers and fixed interval preventive maintenance: a hybrid approach of simulation and metaheuristic algorithms. *Simulation*, 95(6), 509–528. doi: 10.1177/0037549718809542
- Rossi, A., Pandolfi, A., & Lanzetta, M. (2013). Dynamic set-up rules for hybrid flow shop scheduling with parallel batching machines. *International Journal of Production Research*, 52(13), 3842–3857. doi: 10.1080/00207543.2013.835496
- Rubmann, M.; Lorenz, M.; Gerbert, P.; Waldner, M.; Justus, J.; Engel, P.; Harnisch, M. *Industry 4.0*; Boston Consulting Group: Boston, MA, USA, 2015.
- Sabuncuoglu, I. (1998). A study of scheduling rules of flexible manufacturing systems: A simulation approach. *International Journal of Production Research*, 36(2), 527–546. doi: 10.1080/002075498193877

- Saeid, M., Krishna, K. K., Vignesh, K., and Id, Jithavech (2009). Simulation modeling and analysis of distributed and process layouts.
- Saravanan, M., Sridhar, S., & Harikannan, N. (2014). Application of Meta-Heuristics for Minimization of Makespan in Multi-Stage Hybrid Flow Shop Scheduling Problems with Missing Operations. *International Review of Mechanical Engineering (IREME)*, 8(5), 916. doi: 10.15866/ireme.v8i5.3296
- Shambu, G., & Suresh, N. C. (2000). Performance of hybrid cellular manufacturing systems: A computer simulation investigation. *European Journal of Operational Research*, 120(2), 436–458. doi: 10.1016/s0377-2217(98)00371-3
- Tang, L., Liu, W., & Liu, J. (2005). A neural network model and algorithm for the hybrid flow shop scheduling problem in a dynamic environment. *Journal of Intelligent Manufacturing*, 16(3), 361–370. doi: 10.1007/s10845-005-7029-0
- Wang, S., Wan, J., Li, D., & Zhang, C. (2016). Implementing Smart Factory of Industrie 4.0: An Outlook. *International Journal of Distributed Sensor Networks*, 12(1), 3159805. doi: 10.1155/2016/3159805
- Xie, C., & Allen, T. T. (2015). Simulation and experimental design methods for job shop scheduling with material handling: a survey. *The International Journal of Advanced Manufacturing Technology*, 80(1-4), 233–243. doi: 10.1007/s00170-015-6981-x
- Zhang, J., Ding, G., Zou, Y., Qin, S., & Fu, J. (2017). Review of job shop scheduling research and its new perspectives under Industry 4.0. *Journal of Intelligent Manufacturing*, 2019(30), 1809–1830. doi: <https://doi.org/10.1007/s10845-017-1350-2> Review